

Product Manual

232-STA

Stereo TV Tuner

Ver. 4.4 May 24, 2008



17630 Davenport Road, Suite 113 • Dallas, TX 75252
Phone: 972-931-2728 • Toll-Free: 888-972-2728 • Fax: 972-931-2765
E-Mail: Sales@crwww.com • Website: www.crwww.com

Table of Contents

Overview	3
New Features (Rev 3.3-4.0)	3
Specifications	4
Physical	4
Front Panel	4
Rear Panel	4
RF Tuner	5
Includes	5
Options	5
Troubleshooting	6
Front Panel Programming	6
Modes 10 and above	6
Front Panel Programming Commands	7
RS-232 Control Protocol	8
Overview	8
General protocol specifications	8
Command String Structure	8
Command and Status Response.....	8
General RS-232 Commands.....	9
Character Generator Commands	11
Keypad Channel Command.....	12
IC-RC Remote Emulation.....	12
Tune Ring Commands and Replies	13
Terminal Communication Commands	13
RS-232 Command Hints and Tips.....	13
Response Strings	14
Channel/Source Status Response String (T):	14
Audio Status Response String (V):	14
Front Panel Mode Status Response String (S):	14
RS-232 Cable Connections	15
Single Tuner	15
Multiple Tuners	15
Rack Mounting	16
RK1 Single Unit Rack Mount	16
RK2 Side-by-Side Rack Kit	16
Safety Instructions	17
Limited Warranty and Disclaimer	18

Overview



The Contemporary Research 232-STA is a versatile RS-232 controlled video tuner featuring stereo audio, 125-channel access in off-air, CATV, HRC, or IRC modes, front-panel operation and feedback, and intelligent control. Fully programmable, the unit can restore all settings on power-up from non-volatile memory. A list of accessible channels, called channel rings, can be stored in memory, used for convenient channel up/down control and to control direct access to unlisted channels. Switchable inputs for NTSC video and stereo audio are included for display of PC graphics, a character generator information channel, camera or other A/V sources.

The front-panel buttons and alpha-numeric display can be used for general operation and to program basic features for tuning, RS-232 baud rate and local control. Full setup, control, and feedback is provided by RS-232. Up to nine 232-series tuners can be controlled from a single RS-232 port. In addition, remote tuning ring channel up and down operation can be accessed through contact closure inputs.

- Interacts with PCs and control systems via RS-232, using simple ASCII-format commands and feedback, up to 9 tuners can be linked to a single RS-232 control port
- Tunes 125 channels in off-air, CATV, HRC, or IRC modes, using true synchronous video detection and intercarrier SAW filter
- Stores programmable tuning ring in memory to control channel access
- Provides front-panel control for A/V Mute, mode select, and channel up/down, with LED feedback for Mute, current channel and programming mode
- Accesses tuning ring channel up/down from contact closure inputs
- Restores all operation status after loss of power from data stored in non-volatile memory
- Mutes both audio and video with front-panel LED indicator
- Delivers stereo audio with programmable volume, bass, and treble levels, as well as stereo, mono and SAP audio modes
- Switches between tuner and external composite stereo A/V input
- Enables and disables front-panel control via RS-232
- Mounts in 19" rack with optional RK1 or RK2 kit for dual side-by-side installation
- Firmware updateable via modem or PC software (available soon)

New Features (Rev 3.3-4.0)

- Shares new processor from 232-ST5 S-Video Stereo Tuner
- Adds new front-panel (12-14) and RS-232 programming modes (Q2-Q4) to match 232-ST5
- Upgradeable firmware, presently updated via modem from factory, software tools available soon for local update
- Units shipped with new processor start with serial number 223-5009-001, Rev 3.1 or higher
Serial number can be read as follows—xxx (production run) - 5009 (232-STA) – xxx (unit number)
- Request Tune Ring and Channel Label (3.4)
- IC-RC Remote emulation (V3.4)
- Up to 9 units can be controlled from a single RS-232 control port, up to 19.2 Kb (V 3.5)
- Sending a command to Unit#0 (Zero) acts as a global command to all tuners (V4.0)

Specifications

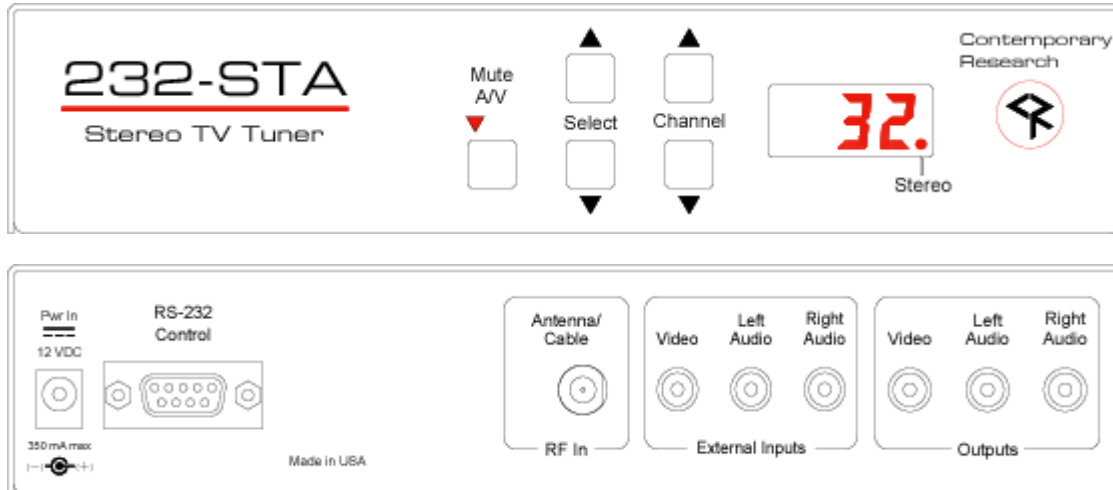

Physical

Size:	8.5" [216mm] wide x 1.75" [38mm] height (1RU) x 6.0" [153mm] deep
Weight:	1.5 lbs [0.68kg]
Enclosure:	All aluminum with durable black powder coat paint
Mounting:	Rack mounting for one or two units side-by-side optional (RK1, RK2)

Front Panel

Mute A/V:	Toggles audio and video mute on/off, blanks all video and audio when active
Mute LED:	Red LED lights when A/V is muted
Volume:	Up and down buttons raise and lower volume
Channel:	Up and down buttons select channels from stored tuning ring
Display:	Red LED 3 digit, 7 segment alphanumeric display for channels and modes

Rear Panel

Power In:	2.1mm coaxial jack (inside center conductor positive), 350 mA maximum 11.5 to 16.5 VDC, 12 VDC typical (may be unregulated) North American version includes UL/CSA listed wall power supply
RS-232 Control:	DB-9 male connector, baud rates from 300 to 9600 baud User selectable 300 to 19,200 (9600 default) baud, 8 data bits, no parity, 1 stop bit Employs standard ASCII strings from any terminal program, PC, or control system 2 momentary closure inputs - Channel Up (Pin 4), Down (Pin 9), GND (Pin 5)
Antenna/Cable:	'F', female, 75 ohm impedance
Video Input:	RCA female, NTSC composite
Video Output:	RCA female, NTSC composite, 75 ohm impedance, 1V peak-to-peak typical
Audio Outputs:	2 RCA female, stereo 1K ohms, unbalanced, 1K ohm impedance Selectable for stereo, mono and SAP modes
Response:	Stereo/SAP: Total Harmonic Distortion (THD): 1% maximum, 0.3% typical Channel Separation: 25dB minimum, 30dB typical, 50Hz to 12KHz Mono: Total Harmonic Distortion (THD) 0.5%, 0.1% typical 20Hz to 20KHz
Level:	500 mV RMS typical output level (at max volume) Volume control 0 to -70 dB and mute in 64 steps

Specifications

RF Tuner

Frequency Range: NTSC television 55.25 to 801.25 MHz, 62.5KHZ fine tune resolution
Maximum Input: Maximum Input: +20dBmV max, +10dBmV nominal*
Video Gain: ±5% maximum, 2% typical
Video Phase: ±3 degrees maximum, 2 degrees typical

*All tuners with firmware V3.7 to V4.1 made between Apr and Nov 2005 should be upgraded to new V4.3 (or higher) to ensure higher RF input level specs and best video performance.

Includes

12 VDC power supply, 400 mA min (North American shipments only)

Options

Onscreen text/captioning – use 232-STS

CC-232 RS-232 Control Cable (specify make and model)

RK1 Kit for mounting single unit in 19" rack, RK2 Kit for mounting two units side-by-side in 19" rack

Troubleshooting

Symptom: Front-Panel Channel Up does not operate, advances one channel when powered

The RS-232 port has contact closures for Channel Up and Down on pins 4 and 9. Off-the shelf RS-232 control cables (such as consumer null modem cables) that include those wires can lock up channel operation. If the problem clears up when you unplug the RS-232 cable, use a cable with only 3 wires for GND, Transmit, and Receive.

Symptom: Problems with Cable Channels

There are three types cable channel systems, Cable, IRC, and HRC. While the Cable setting works for over 90% of installations, there are a few cable systems set for IRC and HRC channel frequencies. Here's how to tell which is which:

- **IRC**– Channels 5 and 6 are missing. Change to IRC and they will appear.
- **HRC** – None of the channels work. Change to HRC.

Front Panel Programming

To Enter a Front Panel Programming Mode:

1. Press **and hold** the Mute A/V button such that the red LED light above is lit (indicating Mute On).
2. Press Volume Up.
3. Release all buttons, the 232-STA will now be in the front panel programming mode.
4. The front panel display is dedicated to programming information display while in this mode.
5. Changes are saved in non-volatile memory as they are entered.
6. The Volume up/down buttons scroll through programming modes 0 through 9 and 10+.
7. The Channel up/down buttons scroll through possible parameters for each mode.

To Exit the Front Panel Mode

Push and release the Mute All A/V button.

Modes 10 and above

When you select programming mode 10 and above, the Mode digit and decimal point will flash. For example, if Mode 14 is selected, the display will show a flashing **4.** - followed by the current parameter setting.

Modes 10 – 14 are identical to RS-232 Commands Q0 – Q4, included for RS-232 programming compatibility with the 232-ST5. Most functions are fixed, Mode 13 is the only function that can be changed in the 232-STA.

Front Panel Programming Commands

Mode	0-9	Parameters	Mode	10+	Parameters
RF Tune	0.0 0.1 0.2 0.3	CATV Broadcast HRC IRC	Caption Type	10.0 10.1 10.2	Captioning off (fixed) No function No function
Baud Rate	1.1 1.2 1.3 1.4 1.5 1.6 1.7	300 600 1200 2400 4800 9600 19,200 (V3.5)	Caption Mode	11.1 11.2 11.3 11.4 11.X	No function (default) No function No function No function No function
Unit Number	2.1 2.2 2.3 2.x	One Two Three Four – Nine (V3.5)	Video Detect	12.3	No function (fixed)
Not Used	3.0		AV Status	13.0 13.1 13.2 13.3	No AV status (default) Stereo/Mono status Disable S/M status Enable S/M status
Panel Lockout	4.0 4.1 4.2 4.3 4.4 4.5 4.6 4.7	None Channel up/dwn Volume up/dwn Channel & Volume up/dwn Mute A/V Channel up/dwn & Mute A/V Volume up/dwn & Mute A/V All	Label Mode	14.0 14.1 14.2 14.3	No function No function No function (default) No function
Power-up Volume	5.0 5.X	restore previous level 1 – 63 sets volume level			
Firmware Version	6.40	Ex: Version 4.0 - Press and hold Channel Up, then Mute AV to restore tuner to default settings			
Audio Decode	7.0 7.1 7.2 7.3	Mono both channels Left/right stereo Mono/SAP SAP/SAP			
Bass Gain	8.0 8.X	-12 dB bass level 0-19 sets bass -12 to 16.5dB			
Treble Gain	9.0 9.X	-12 dB treble level 0-8 sets treble, -12 to 12 dB			

Bass Level Settings			
Level	Gain (dB)	Level	Gain (dB)
19	16.5	9	1.5
18	15.0	8	0
17	13.5	7	-1.5
16	12.0	6	-3.0
15	10.5	5	-4.5
14	9.0	4	-6.0
13	7.5	3	-7.5
12	6.0	2	-9.0
11	4.5	1	-10.5
10	3.0	0	-12.0

Treble Level Settings	
Level	Gain (dB)
8	12
7	9
6	6
5	3
4	0
3	-3
2	-6
1	-9
0	-12

RS-232 Control Protocol

Overview

The 232-STA full duplex RS232 scheme enables a system programmer to control all TV Tuner functions as well as monitor 3 groups of TV Tuner status. All commands are sent as ASCII strings. No delays between characters or commands are required, as data is interrupt driven and buffered.

The 3 status groups are: Channel/Source Select, Audio Levels/Mode and Front Panel. The Mute A/V button-function status from the 232-STA front panel has been grouped with the Channel/Source for simplicity in the most common modes of operation. Each of the groups has one ASCII status response string containing all of the status data for that group. The current status string of a group is sent from the 232-STA whenever a valid command for that group is received by the 232-STA RS-232 port or front panel. A group's status may be requested at any time via the RS-232 port. Status of all 3 groups is sent at power up. The format of each group's status response string remains the same always.

Up to 9 232-STAs may be cabled together and addressed for individual control from a single RS-232 port. Each 232-STA is assigned a unique unit code (Front Panel Mode 2).

Communications parameters (Front Panel Mode 1) are 300 to 9600 baud, 8 data bits, No parity, and 1 stop bit. Factory default is 9600 baud, Unit#1.

All settings are saved to NVRAM in the 232-STA.

General protocol specifications

Characters in command strings to the 232-STA are common ASCII keyboard characters.

Command strings sent to the 232-STA begin with the ASCII > (greater than symbol) as an 'Attention' character and end with carriage return - ASCII CR, Hex \$0D, or keyboard Enter - as an 'End-of-command' character. Responses from the 232-STA begin with the ASCII < (less than symbol) as an 'Attention' character and end with a carriage return followed by line feed an ASCII LF or Hex \$0A as 'End-of-command' characters. A carriage return is required at the end of each command and is assumed in all examples.

Command String Structure

[Attention] (Unit#) [Command] (Parameters) [Return]

Attention	Single character (>) starts the string
Unit#	The Unit# is expressed as an ASCII 0-9 when used in multiple tuner applications. To address all units, use a Unit # of 0 (Zero – versions 4.0 and above) Sending no unit number will default to Unit#1
Command	A two-character command
Parameters	Added attributes to some commands
Return	A carriage return ends the command string, you may use ASCII CR, Hex \$0D, or keyboard 'Enter' in programming. For simplicity, the programming examples in the manual will not show the 'CR' – so remember, you'll need to add it in your control code.

Command and Status Response

Commands can be sent back to back at any time without any delay. To allow for rapid, multiple commands, status responses are intentionally delayed by about 125mS, sending the most current status in response to control commands or user actions.

General RS-232 Commands

Q	Q-series commands	Included for compatibility with 232-STC programming. As the STA does not have on-screen text or video detection, most commands will have no affect in tuner operation.
Q0=	Caption Mode Off (0-2)	Sets captioning mode 0=Captioning off (fixed)
Q1=	Captioning Type (1-8)	Turns on captioning type, no functionality in 232-STA 1=Caption 1 (default) 2=Caption 2 3=Caption 3 4=Caption 4 5-8= Text 1-4 (rarely used)
Q2=	Video Loss Detection (0-3)	Selects response when a loss of video signal is detected 3=No Function (fixed)
Q3=	A/V Detect Status (0-3) Example: '>Q3=1' or '>Q31'	Enables/disables sending status response when Stereo/Mono or Video Loss Detect changes. Only status operation is affected, the functions continue to operate. 0=Disable Stereo/Mono detection(default) 1=Enable Stereo/Mono 2=Disable Stereo/Mono 3=Enable Stereo/Mono
Q4=	Label Mode with Status (0-3)	0= No Function 1= No Function 2= No Function (default) 3= No Function
TR=	Set Tune Ring (TR) Example: '>2TR=2,4,7-10'	Limits access to specified channels, 120 chars max Stores unit#2 Tune Ring as 2,4,7,8,9,10
TT=	Select tuned channel (0-126) Example: '>TT=28'	0=video mute, 255=video unmute* 126=External AV Inputs Selects channel 28 only if 28 is present in current TR
TC=	Force tuned channel (0-126) Example: '>TC=39'	0=video mute, 255=video unmute* 126=External AV Inputs Selects channel 39 regardless of current TR
TP	Set to previous channel	Selects previous channel only if present in current TR
TU	Tune channel up Example: '>3TU'	Selects next higher channel in stored Tune Ring Bumps Unit#3 tuned channel up one from available Tune Ring
TD	Tune channel down	Selects next lower channel in stored Tune Ring
XT	Toggle Mute A/V	Alternates Mute A/V on and off
XX	Mute A/V off	Turn A/V outputs on at previous level
XM	Mute A/V on Example: '>XM'	Mutes A/V outputs Mutes audio and video outputs
P0	Power Off	Same as XM
P1	Power On	Same as XX
PT	Power Toggle	Same as XT

* If the optional character generator is installed, Video Mute will display a blue screen, useful as a character background. Without a CG, Video Mute will blank the video output. The Video Mute command does not mute the audio.

General RS-232 Commands

VU	Ramp volume up	Starts volume ramping up
VD	Ramp volume down	Starts volume ramping down
VL	Ramps volume to level (0 – 63)	Sets volume to specific level
VX	Volume Mute off	Restores audio volume to previous level
VV	Stop volume ramp	Stops volume ramping
VT	Toggle Volume Mute	Alternates audio mute on and off
VM	Volume Mute on <i>Example:</i> '>VM'	Turns off audio outputs Mutes audio outputs
S0=	Set tune mode	0=CATV 1=Broadcast 2=HRC
S4=	Set front panel lockout mode	0=None 1=Channel 2= Volume 3=Channel & Volume 4=Mute A/V 5=Channel & Mute A/V 6= Volume & Mute A/V 7=All
S5=	Power-up volume	0=restore to previous level 1-63= Restore to preset volume level (1 min, 63 max)
S7=	Set audio mode	0=Mono/Mono, 1=Stereo, 2=Mono/SAP, 3= SAP/SAP
S8=	Set bass gain level (0-19)	See Bass Level chart on page 6
S9=	Set treble gain level (0-8)	See Treble Level chart on page 6
SS	Request Front Panel status	Unit sends "S" Front Panel status string
ST	Request Channel status <i>Example:</i> '>ST'	Unit sends "T" Channel/Source status string Returns Channel/Source status response string
SV	Request A/V status	Unit sends "V" Audio status string

A carriage return is required at the end of each command and is assumed in all examples. The '=' sign for parameters may be omitted if desired, though it is helpful for clarity in checking programming.

Character Generator Commands

Before the introduction of the 232-ST5, 232-STA models offered an optional character generator, supporting an on-screen display that is 28 columns (characters) across by 11 rows (lines) down. An imaginary cursor represents the current screen write position. Writing text automatically increments the cursor to the next character space. The character text is always white.

TM= <label mode>	<p>Sets on-screen channel label mode.</p> <p>0=None 1=Alpha only 2=Numeric only 3=Both alpha and numeric labels</p> <p>Channel labels are displayed overlaying the video in the top-left corner of the screen for about 10 seconds after each channel change.</p> <p><i>Example:</i> '>TM=2' Sets channel mode to display channel number only.</p>
TN= <channel> , <alpha label>	<p>Sets the alpha label for the specified channel. Alpha labels may be up to 8 characters and are displayed on screen when a channel changes, if alpha labels are enabled by the 'TM' command.</p> <p><i>Example:</i> '>TN=8,ABC' Sets the alpha label for channel 8 to be 'ABC'.</p>
TN=0,0	Clears (blanks) all stored alpha labels
TC	Displays the current channel label on screen for about 10 seconds
DG= <row> , <column>	Moves the cursor to the specified row and column position. If row is 0, then row will not be changed, and if column is 0, then column will not be changed.
E7= <column>	Moves cursor to specified column.
E8= <row>	Moves cursor to specified row.
EA	Clear on screen display. Also, moves cursor to column 1 and row 1.
EB	Moves cursor down to the first column of the next row (like a carriage return plus line feed).
DC	Clear on screen display from the cursor to the end of the screen. Cursor position does not change.
DB	Clear on screen display from the cursor to the end of the current line. Cursor position does not change.
E9= <num spaces>	Clears the specified number of spaces. Cursor position does not change
DM	Clears on-screen display. Also, moves cursor to column 1 and row 1, unblanks screen if it was blanked, and cancels an active 'KC' or 'KT' keypad command
DN<text>	Clears on screen display, then writes the specified text to the display starting at column 1 and row 1.
DW<text>	Writes the specified text to the display starting at current cursor position.
DQ= <time>	Sets screen timeout to specified time in seconds. If time is 0 or 255, any text on the screen will persist indefinitely, or until cleared.

Keypad Channel Command

If you're using an external control system, this command will emulate the pressing of numeric keypad buttons for channel selection, which means you won't need to use extra elements for capturing channel commands in your programming. The **KC** command will access any channel, **KT** will only access a channel stored in the Tune Ring.

KC=0	Emulates '0' key, accesses any channel.
KC=1	Emulates '1' key, accesses any channel.
KC=9	Emulates '9' key, accesses any channel.
KC	Emulate 'Enter' key, accesses any channel.
KT=9	Emulates '9' key, accesses channel if it exists in current Tune Ring.
KT	Emulate 'Enter' key, accesses channel if it exists in current Tune Ring.
KD	Clears or cancels any KC or KT channel entry

After 3 seconds, with no other key, the selected channel will be tuned to. Optionally, you can have an Enter key send the command KC or KT to select the channel immediately. Using the KD command can cancel a channel entry before the time delay or Enter executes the channel change.

IC-RC Remote Emulation

You can also emulate IR commands sent from the CR IC-RC Wireless Remote. If you are using the numeric keys to select a channel, the user or program will need to follow the numeric command with an Enter.

KK=<key>	Emulates IC-RC remote key codes 0=Release Key 9=Power (toggling) 10= 0 (numeric keypad) 11=1 12=2 13=3 14=4 15=5 16=6 17=7 18=8 19=9 21=Enter 22=Channel up or + 23=Channel down or - 24=Volume up or + (use Release Key (0) to stop volume ramp) 25=Volume down or - (use Release Key (0) to stop volume ramp) 26=Volume mute 30=Switch to tuner AV (previous channel) if unit is currently set to External AV 31= Input (toggling)
-----------------------	--

Tune Ring Commands and Replies

\$R	Request Tune Ring	Asks for reply with list of channels in Tune Ring <i>Example:</i> '>\$R' asks for list from Unit 1 <i>Reply:</i> '<1\$TR2-31,35,52,126'
\$N=xxx	Request Label	Asks for reply with channel text assigned to specific channel <i>Example:</i> '>\$N31' asks for label assigned to channel 31 <i>Reply:</i> '<1\$TN038,ABC'

Terminal Communication Commands

EF	Echo Off	Characters received will not be re-transmitted (power up default)
EN	Echo On	Characters received will be re-transmitted. <i>Example:</i> '>EN' Characters received will be re-transmitted.
ID	Product ID	Returns the product model number and software version.
Z!	Zap	Reconfigures unit for all factory default settings.

RS-232 Command Hints and Tips

Leading zeros may be included or omitted from command parameters.

Example: '>TC=009' Selects channel 9 as A/V output, same as '>TC=9'.

Multiple commands may be concatenated as single strings up to 120 ASCII characters long.

Example: '>XXTC=9' Selects Mute A/V off, channel 9.

Example: '>S0=0S4=0' Selects CATV mode, no front panel lockout.

Mute A/V Off command is not required in any command; however it may be useful to send Mute A/V Off in case Mute A/V had been set On from the front panel.

Sending all 3 status request commands to the 232-STA back-to-back for a full status update is allowed.

Example: '>STSVSS' Returns all 3 response strings back-to-back.

The carriage return line feed at the end of each 232-STA response allows for easy monitoring of responses with an ASCII terminal program. You may use ASCII CR, Hex \$0D, or keyboard 'Enter' in programming.

You don't have to use the '=' character between the command and parameter – the string works either way.

Response Strings

Typical: [Attention] [Unit#] [data ...data] [cr] [lf]

232-STA status response strings contain ASCII characters similar to those used for the same functions in command strings. An ASCII 'carriage return' and 'line feed' follow each response string. Functions shown as N/A are not applicable; characters will appear in status strings as lower-case x.

Channel/Source Status Response String (T):

Start	Unit	CMD	Power	Channel	Video Mute	N/A
	1-9		U=On M=Off	Current Channel 3 digits	U=Unmuted M=Mute	2 digits
<	1	T	U	008	U	xx

Audio Status Response String (V):

Start	Unit	CMD	Power	Volume	Volume Mute	Stereo
	1-9		U=On M=Off	0-63 2 digits	U = Unmuted M =Mute	S=Stereo M=Mono
<	1	V	U	63	U	S

Front Panel Mode Status Response String (S):

Start	Unit	CMD	Audio Mode	Audio	Tune Mode	Lockout	Bass	Treble
	1-9		0=Mono/Mono 1=Stereo 2=Mono/SAP 3=SAP/SAP	S=Stereo M=Mono	0-3	0-9	0-9 2 digits	0-8
<	1	S	1	S	0	1	08	4

RS-232 Cable Connections

Single Tuner

Control Wiring – Single Unit

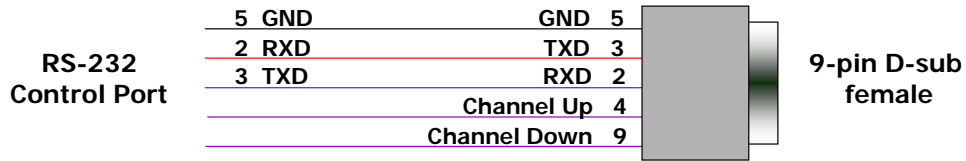

RS-232 wiring for control or programming should only use pins 2, 3, 5. Cables with all pins wired can lock out front-panel programming and data communication (Pins 4 and 9 are inputs).

Multiple Tuners

Up to nine tuners can be daisy-chained from one RS-232 control port. Remember that you will need to use the Unit# address in your programming when you control more than one tuner from the same control port.

Set the first unit in the RS-232 chain to the highest Unit#, then wire in sequence to the last tuner in the chain. The reason for this is that CR tuners use an intelligent data bus - the highest number tuner receives all commands, and then passes on commands addressed to tuners with lower unit numbers. The next tuner in the chain does the same, and so on until the last unit.

RS-232 Wiring – Two Units

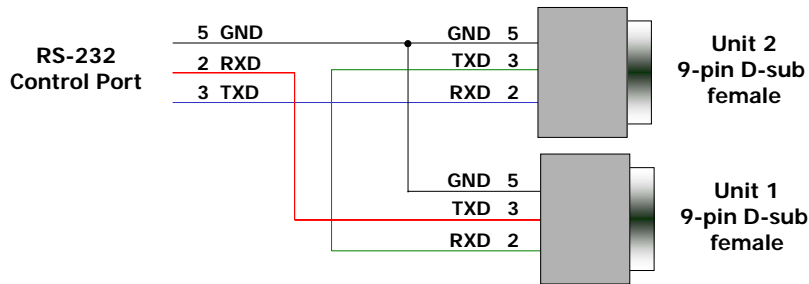

RS-232 Wiring – Three Units

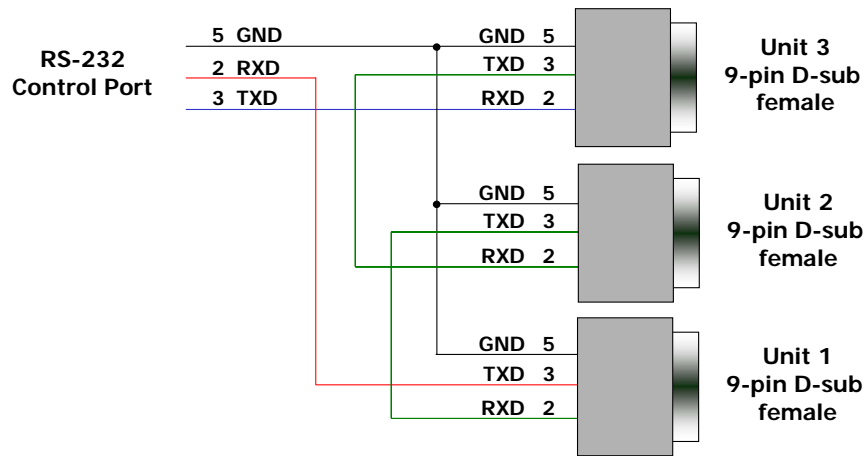

Rack Mounting

Two options are available for rack-mounting tuners.

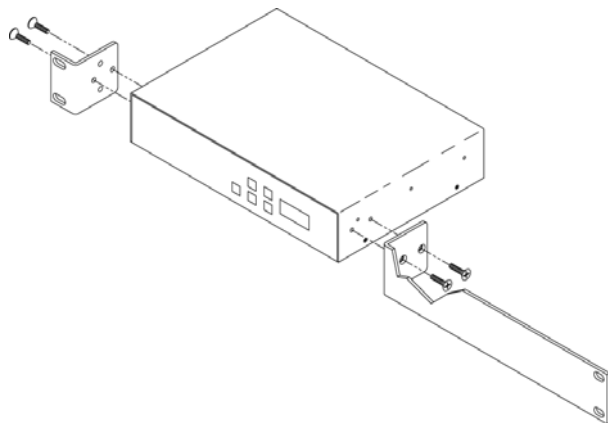

RK1 Rack Mount

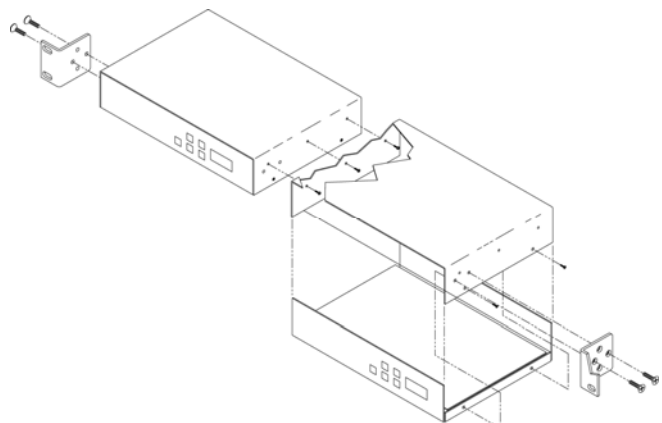

RK2 Rack Mount

RK1 Single Unit Rack Mount

Size Long Bracket:	9.5" [206mm] wide x 1.75" [38mm] height (1RU) x 1.75" [38mm] deep
Size Short Bracket:	1.0" [22mm] wide x 1.75" [38mm] height (1RU) x 1.75" [38mm] deep
Weight:	3.25 oz [0.148kg]
Enclosure:	All aluminum with durable black powder coat paint
Hardware:	Qty 4 CS, Phillip, Flathead, 82deg, Black, 8-32 x .25"

Attach the long and short rack ears to the side and towards the front of the unit with the four (4) supplied 8-32 by 1/4" (black) countersunk screws.

RK2 Side-by-Side Rack Kit

1. Remove top cover of the first unit by removing the ten (10) black screws.
2. Attach cover of first unit to the side of the second with three (3) supplied 4-40 by 1/4" (silver colored) panhead screws and split lock washers. Note that only one side of the second unit has the (3) built in nuts to accept the screws above.
3. Reinstall the bottom/chassis of the first unit underneath its cover and attach with just eight (8) of the screws removed in step 1.
4. Attach short rack ears to the side and towards the front of each unit with the four (4) supplied 8-32 by 1/4" (black) countersunk screws.

Safety Instructions

Read before operating equipment.

1. **Cleaning** - Unplug this product from the wall outlet before cleaning. Do not use liquid cleaners or aerosol cleaners. Use a damp cloth for cleaning.
2. **Power Sources** - Use supplied or equivalent UL/CSA approved low voltage DC plug-in transformer.
3. **Outdoor Antenna Grounding** - If you connect an outside antenna or cable system to the product, be sure the antenna or cable system is grounded so as to provide some protection against voltage surges and built-up static charges. Section 810 of the National Electrical Code, ANSI/NFPA No. 70, provides information with respect to proper grounding of the mast and supporting structure, grounding of the lead-in wire to an antenna discharge unit, size of grounding conductors, location of antenna discharge unit, connection to grounding electrodes, and requirements for the grounding electrode.
4. **Lightning** - Avoid installation or reconfiguration of wiring during lightning activity.
5. **Power Lines** - Do not locate an outside antenna system near overhead power lines or other electric light or power circuits or where it can fall into such power lines or circuits. When installing an outside antenna system, refrain from touching such power lines or circuits, as contact with them might be fatal.
6. **Overloading** - Do not overload wall outlets and extension cords as this can result in a risk of fire or electric shock.
7. **Object and Liquid Entry** - Never push objects of any kind into this product through openings as they may touch dangerous voltage points or short out parts, resulting in a fire or electric shock. Never spill liquid of any kind on the product.
8. **Servicing** - Do not attempt to service this product yourself as opening or removing covers may expose you to dangerous voltage or other hazards. Refer all servicing to qualified service personnel.
9. **Damage Requiring Service** - Unplug this product from the wall outlet and refer servicing to qualified service personnel under the following conditions:
 - When the power supply cord or plug is damaged.
 - If liquid spills or objects fall into the product.
 - If the product is exposed to rain or water.
 - If the product does not operate normally by following the operating instructions. Adjust only those controls that are covered by the operating instructions. An improper adjustment of other controls may result in damage and will often require extensive work by a qualified technician to restore the product to its normal operation.
 - If the video product is dropped or the cabinet is damaged.
 - When the video product exhibits a distinct change in performance, this indicates a need for service.

* **Note to CATV system installer:** This reminder is provided to call CATV system installer's attention to Article 820-40 of the National Electrical Code (Section 54 of Canadian Electrical Code, Part I), that provides guidelines for proper grounding and, in particular, specifies that the cable ground shall be connected to the grounding system of the building as close to the point of cable entry as possible.

Limited Warranty and Disclaimer

Contemporary Research Corporation (CR) warrants this product to be free from defects in material and workmanship under normal use for a period of two years from the date of purchase from CR. Should such a defect occur CR will repair or replace, at their option, the defective product at no cost for parts or labor.

This warranty extends to product purchased directly from CR or an Authorized CR Dealer. Consumers should inquire from selling dealer as to the nature and extent of the dealer's warranty, if any.

All warranty claims must be shipped pre-paid to the factory. Call or fax to obtain a Return Material Authorization (RMA) number.

CR is not liable for any damages caused by any of its products or for the failure of any products to perform, including any lost profits, lost savings, incidental damages, or consequential damages. CR is not responsible for any claim made by a third party or made for you by a third party. This limitation of liability applies whether damages are sought, or a claim is made, under this warranty or as a tort claim (including negligence and strict product liability), a contract claim, or any other claim. This limitation of liability cannot be waived or amended by any person. This limitation of liability will be effective even if CR or an authorized representative of CR has been advised of the possibility of any such damages.

Some states do not allow a limitation of how long an implied warranty lasts. Some states do not allow the limitation or exclusion of incidental or consequential damages for consumer products. In such states, the limitation or exclusion of the Limited Warranty may not apply to you. This Limited Warranty gives you specific legal rights. You may also have other rights that may vary from state to state. You are advised to consult applicable state laws for a full determination of your rights.

Except as expressly set forth in this Limited Warranty, CR makes no other warranties, expressed or implied, including any implied warranties of merchantability or fitness for a particular purpose. CR expressly disclaims all warranties not stated in this Limited Warranty. Any implied warranties that may be imposed by law are limited to the terms of this Limited Warranty.